

PROPRIETARY DESIGN RIGHTS

THIS DRAWING (PRINT, DISK), INCLUDING THE PRINCIPLE OF DESIGN, IS THE PROPERTY OF AND SUBMITTED BY ABRASIVE WEST LLC. IT IS NOT TO BE REPRODUCED OR COPIED IN WHOLE OR IN PART, REGARDLESS OF HOW ACCOMPLISHED, OR USED FOR FURNISHING INFORMATION TO OTHERS, OR FOR ANY OTHER PURPOSE DETRIMENTAL TO THE INTEREST OF ABRASIVE WEST LLC.

OPERATION DESCRIPTION:
CUT-OFF TO INDIVIDUAL PCS

OP-600

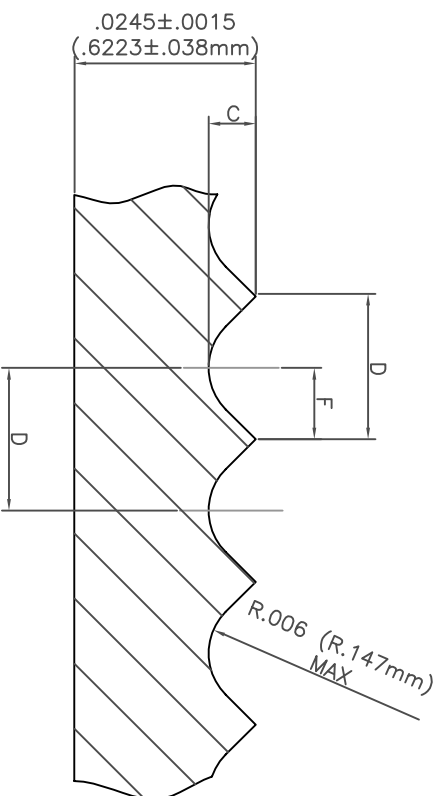
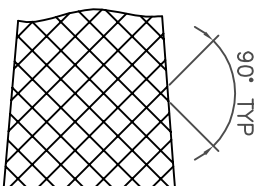
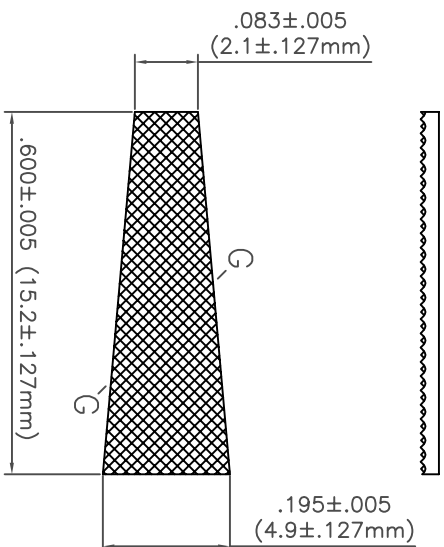

SECTION G-G ROTATION 45°

PART NUMBER	MATERIAL	TEETH (PER SQUARE INCH)	DIMENSIONS (INCH & MM)		
			C $\pm .0015"$ ($\pm .038$ mm)	D $\pm .001"$ ($\pm .025$ mm)	F $\pm .001"$ ($\pm .025$ mm)
195-C-00000-024	VC 011	0 (SMOOTH)	0	0	0
195-N-00000-024	VC 320	0 (SMOOTH)	0	0	0
195-C-02500-024	VC 011	2,500	.0097" (.246mm)	.020" (.508mm)	.010" (.254mm)
195-N-02500-024	VC 320	2,500	.0097" (.246mm)	.020" (.508mm)	.010" (.254mm)
195-C-03600-024	VC 011	3,600	.0093" (.236mm)	.0167" (.424mm)	.008" (.212mm)
195-N-03600-024	VC 320	3,600	.0093" (.236mm)	.0167" (.424mm)	.008" (.212mm)
195-C-07000-024	VC 011	7,000	.0090" (.229mm)	.0119" (.302mm)	.0059" (.151mm)
195-N-07000-024	VC 320	7,000	.0090" (.229mm)	.0119" (.302mm)	.0059" (.151mm)
195-C-10000-024	VC 011	10,000	.0041" (.104mm)	.0100" (.254mm)	.005" (.127mm)
195-N-10000-024	VC 320	10,000	.0041" (.104mm)	.0100" (.254mm)	.005" (.127mm)
195-C-14400-024	VC 011	14,400	.0036" (.091mm)	.0083" (.211mm)	.0042" (.106mm)
195-N-14400-024	VC 320	14,400	.0036" (.091mm)	.0083" (.211mm)	.0042" (.106mm)

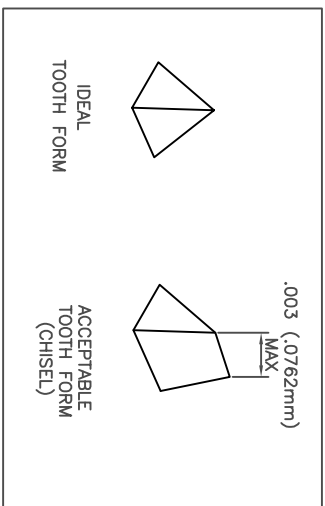

MATERIAL	COMPOSITION
VC 011	COBALT TANTALUM CARBIDE TUNGSTEN CARBIDE BALANCE
VC 320	NICKEL TUNGSTEN CARBIDE BALANCE

UNLESS OTHERWISE NOTED:

.XX = $\pm .010$
 .XXX = $\pm .005$
 .XXXX = $\pm .0002$
 ANGLES $\pm 1'$
 INTERNAL $R_s = .035$ max
 BREAK EDGES .030min
 SURFACE FINISH 64 U.O.S.

CUSTOMER: CARBIDE

P/N

AutoCad

SCALE: N.T.S.

PART NAME:

CARBIDE INSERT

Drawn by:
RLC

DATE: 4/7/99



ABRASIVE WEST LLC
 1292 HUMBRACHT CIRCLE, UNIT F, BARTLETT, IL 60103
 (630)-736-0818 FAX(630)-736-0883

ACAD DWG #
OP-600-195-024

REV	CHANGE	DATE	BY
1	-	-	-